

Application Examples

Fluorescence-correlation Spectroscopy

Advances in laser technology and high performance computers are allowing dramatic progress in research that studies the behavior of single molecules. Fluorescence-correlation spectroscopy is one technique for measuring single molecules. The principle of fluorescence-correlation spectroscopy was conceived in the 1970s, but it wasn't until the 1990s that the proper equipment was around to use it. The equipment structure is largely the same as the confocal laser microscope but there is no Galvano mirror, and only small area of solution is observed. The movement of the fluorescent molecules entering and leaving the area subject to observation and the fluorescent intensity are measured by auto correlation algorithm.

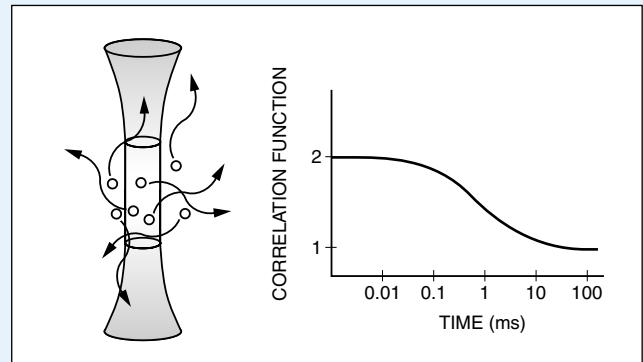

TPMOC0135EB

Vital characteristics

- High quantum efficiency
- Less after pulse

PMT module

- H7421-40 (p. 40)

Laser Radar

One use of laser radar (often called "Lidar") is making atmospheric measurements. A laser beam is emitted into the atmosphere and the light scattered by the "atmospheric molecules" and "suspended elements" then detected. The scattered light is absorbed by "trace gases" during its return and is therefore extremely faint. These "trace gases, and the distribution and concentration of suspended elements" can be analyzed by measuring this faint light. Lidar is actually used in measurements of aerosol and ozone concentrations, CO₂, SO₂ and NO_x concentrations, wind velocity and also the extent of visibility.

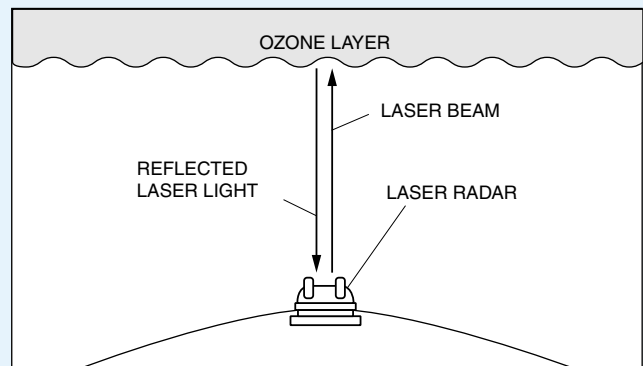

TPMOC0136EA

Vital characteristics

- Gated operation
- Less after pulse

PMT module

- H7680 Series (p. 52)
- H7360-01 (p. 48)

Hygiene Monitor

The hygiene monitor is also called an ATP analyzer. This device extracts the ATP held in bacteria and cells and makes measurements by causing a reaction with the luminous reagent in the ATP using the firefly's light emission principle. This hygiene monitor is used for making purity checks at restaurants and factories producing foods, etc. In the test, the surface of the object for inspection is wiped with a cotton swab and the extent of dirt or contamination immediately found just by inserting the swab in the sanitary monitor. A great feature of the hygiene monitor is that the photon counting method allows highly sensitive measurements using just an extremely small amount of sample material.

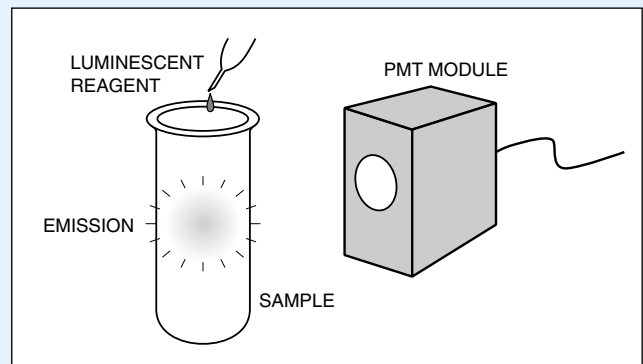

TPMOC0137EA

Vital characteristics

- Compact and light weight
- Low power consumption

PMT module

- H7828 (p. 46)
- H7710 Series (p. 22)

Multi-Photon Microscope

In this method, fluorescent molecules can be excited with near infrared light by letting the molecules absorb two photons almost simultaneously, and the resulting visible to UV fluorescence is observed. The cross sectional area absorbing the two photons is extremely small, so nearly all the fluorescence must be detected as a signal at any position from the focal point. Other advantages are that nearly twice the wavelength is used compared to excitation by one photon. This not only means that unwanted effects from scattering and background noise inside the sample due to excitation light are drastically reduced but also that damage to cells from UV light is minimized.

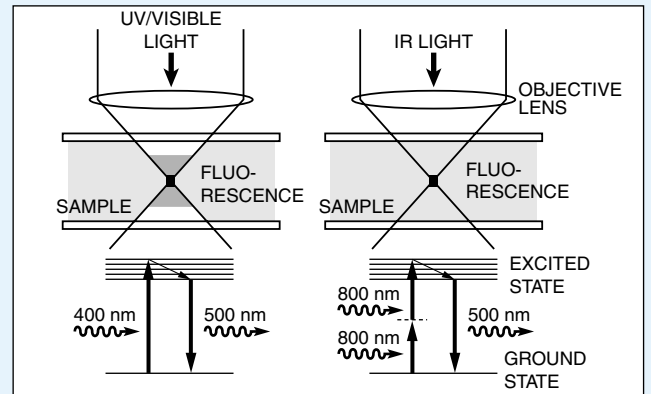

Vital characteristics

- High quantum efficiency

PMT module

- H7422-40 (P. 18)
- H7710-03 (P. 22)

X-ray Image Readout

Devices used to read X-ray images consist of a method using a brightness storage phosphor plate and a method for directly reading X-ray film. The brightness storage phosphor plate can temporarily store the X-ray information that was detected. The stored information on the plate is scanned by a laser beam and then extracted by measuring the fluorescent intensity with PMT modules. The X-ray film is also scanned by a laser beam in the same way and the transmitted light is detected as an electrical signal, which is then converted into a digital signal. These devices can show the X-ray image on a CRT monitor, store and file the image on a disk, or send the image data over a telephone line.

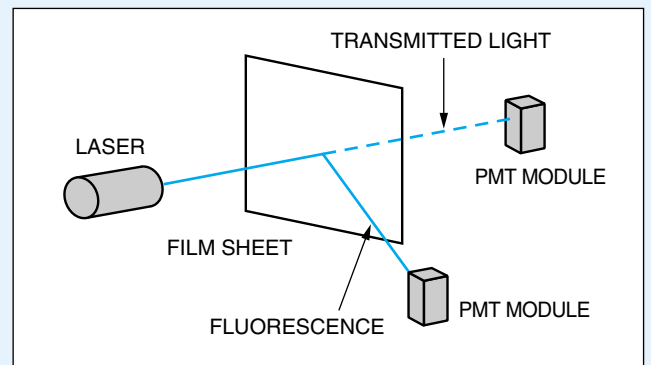

Vital characteristics

- Wide dynamic range
- High sensitivity

PMT module

- H6780-01 (p. 16)
- H7732 (p. 24)

DNA Chip Reader

A DNA chip reader is used to analyze colossal amounts of genetic information. The DNA chip is a substrate on which a large amount of DNA is arrayed usually by a method using semiconductor lithographic technology, or a method dispensing the DNA onto a slide glass using a high-precision robot. On the DNA chip, hybridization is performed on the DNA labeled by a fluorescent dye. The DNA chip is then scanned by laser beam and by measuring the fluorescent intensity of the hybridized DNA spot, the genetic information is acquired from among the targeted DNA. (Hybridization is process to link 2 chains of DNA each having a complementary base.)

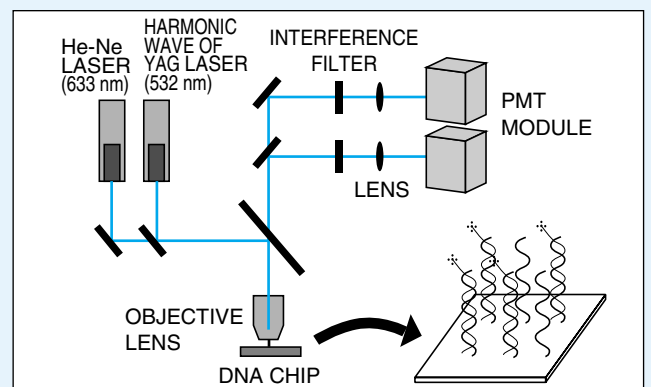

Vital characteristics

- High quantum efficiency
- High-speed response

PMT module

- H7710 Series (p. 22)

▶ Portable Survey Meters

Portable radiation measurement devices or survey meters are essential for detecting radioactive substances for public safety in customs inspections, nuclear power plants, and hospitals, etc. Among various radiation measurement devices, the most sensitive type uses a combination of photomultiplier tube and scintillator and offers sensitivity ranging from several ten to hundreds of times higher than Geiger-Müller counters (GM counters). Photomultiplier tubes used in this application must be compact, rugged, and easily coupled to scintillators, and also have low power consumption.

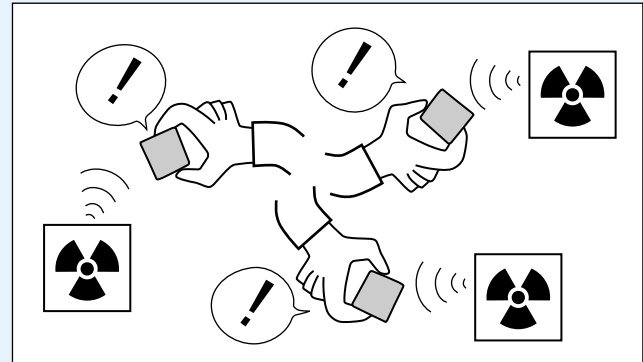

TPMOC0141EA

Vital characteristics

- Compact and light weight
- Vibration-resistant
- Low power consumption

PMT module

- H7826 (p. 26)

▶ Flowcytometers

In a flowcytometers, cells labeled with fluorescent material flow in a solution along a flow cell while moving at a certain interval. A laser beam is then irradiated onto the cells and the scattered light from the cells and fluorescence from the fluorescent material are measured by a photomultiplier tube. Various kinds of information are acquired from the scattered and fluorescence such as cell surface antigens, cell periods, number of cells, immunity functions and reticulocytes, and the cells can also be separated from each other. Rapid advances are recently being made in irradiation by multiple lasers, 6-channel color analysis, high-speed operation, and compact flow systems.

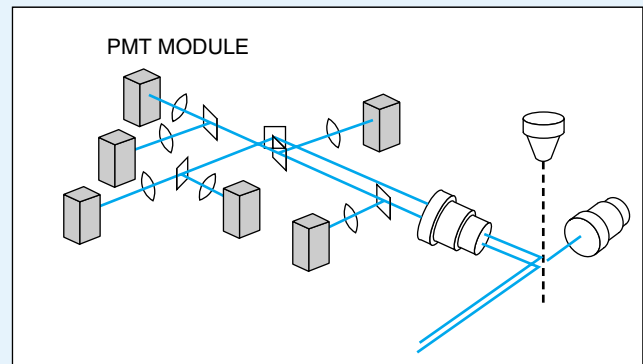

TPMOC0142EB

Vital characteristics

- High-speed response
- High quantum efficiency

PMT module

- H7710 Series (p. 22)
- H6779/H6780 Series (p. 16)

▶ Semiconductor Wafer Inspection Systems

These systems find defects on semiconductor wafers, by scanning a laser beam onto the wafer and then detecting the resulting scattered light to find any debris, dirt or damage on the wafer surface. Advances in semiconductor technology have made lithographic lines on wafers even finer so that even smaller defects must now be detected making these inspection devices an essential tool.

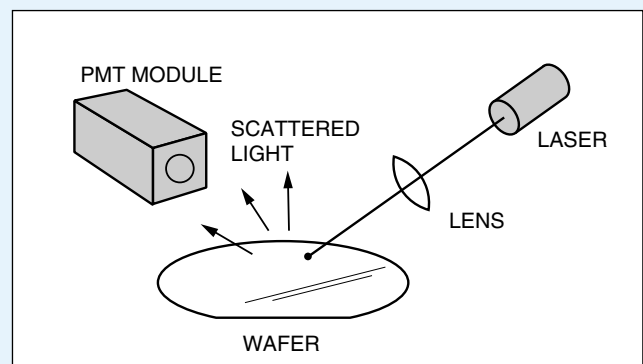

TPMOC0143EA

Vital characteristics

- High-speed response
- Wide dynamic range

PMT module

- H6780-01 (p. 16)

Time-Correlated Single Photon Counting

Time-correlated single photon counting is used to measure low-level light emitted from a sample when excited with a pulsed laser, based on the theory that a histogram obtained by repeatedly measuring the single photon many times at a slightly delayed timing represents a waveform of the emitted light. Electrical signals produced by a laser driver are slightly delayed and used as trigger signals while the PMT module detects the light emission from a sample. The PMT module output pulse signals are then input to a time-to-amplitude converter (TAC) that produces an electrical pulse in proportion to the time difference between a light detection signal and a trigger signal. A multichannel analyzer (MCA) creates a frequency distribution of the output signals from the TAC, to obtain a waveform of the light emission of the sample.

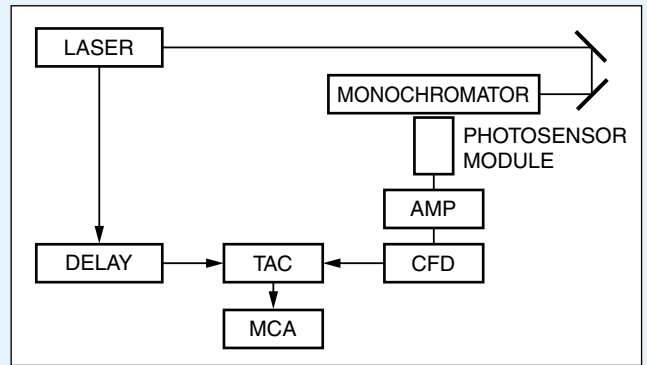

TPMOC0163EA

Vital characteristics

- High-speed response
- High Gain

PMT module

- H5783P (p. 16)
- H7422P Series (p. 18)

Mass Spectroscopy

Mass spectroscopy is an essential measurement technique to analyze samples in various fields such as medicine, pharmacy and environment monitoring. Samples are ionized by vaporization under a high vacuum pressure. The generated ions are accelerated by strong electric fields and sent to a mass analyzer with a strong magnetic field where the ions are separated according to the ratio (m/e) of mass (m) to electron charge (e). Ions with larger molecular weight are detected with a PMT module in conjunction with a scintillator.

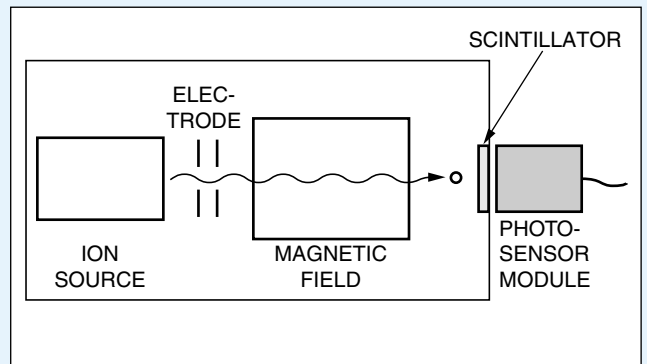

TPMOC0164EA

Vital characteristics

- Wide dynamic range

PMT module

- H5773 (p. 16)

Spectral Radiometers

Spectral radiometers are used to measure spectral distribution, luminance and chromaticity-correlated color temperature of display devices such as LCD and CRT, without making contact with them. Although solid-state photodetectors are commonly used for spectral radiometers, PMT modules enable precision measurement even at low light levels.

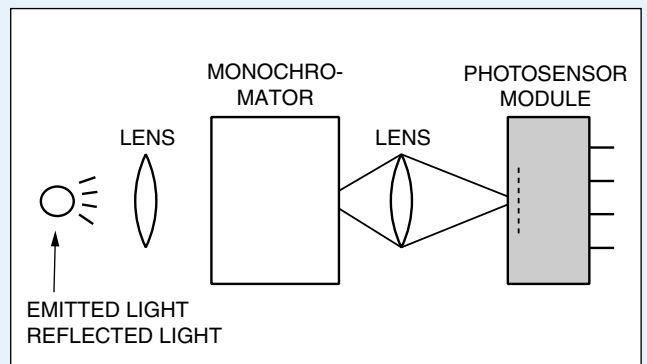

TPMOC0165EA

Vital characteristics

- Compact

PMT module

- H5773 Series (p. 16)