

# Infrared detector Accessory

Wide lineups of accessories for infrared detection

## Temperature controller C1103 series

C1103 series is a temperature controller designed for thermoelectrically cooled infrared detectors. C1103 series allows easy but accurate temperature setting for the thermoelectric cooler mounted in an infrared detector.

### Specifications

Parameter	C1103-04	C1103-05	C1103-07
Applicable detector *1	One-stage/two-stage TE-cooled type PbS, PbSe photoconductive detector, InAs photovoltaic detector, InGaAs, Si, Ge photodiode	Two-stage/three-stage TE-cooled type MCT, InSb photoconductive detector	One-stage TE-cooled type MCT, InSb photoconductive detector
Setting element temperature	-30 to +20 °C	-75 to -25 °C	-30 to +20 °C
Temperature stability	Within ±0.1 °C		
Temperature control output current	1.3 A Max.		
Power supply	100 V ± 10 % · 50/60 Hz *2		
Power consumption	30 W		
Dimensions	105 (W) × 86 (H) × 190 (D) mm		
Weight	1.9 kg approx.		
Accessories	Instruction manual 4-conductor cable (with a connector, 2 m) A4372-05		

\*1: It doesn't correspond to infrared detection module with TE-cooled type preamplifier.

\*2: Please specify power supply requirement (AC line voltage) from among 100 V, 115 V and 230 V when ordering.

### Absolute maximum ratings

Parameter	Value
Operating temperature	+10 to +40 °C
Operating humidity	90 % Max.
Storage temperature	+10 to +40 °C

### Block diagram

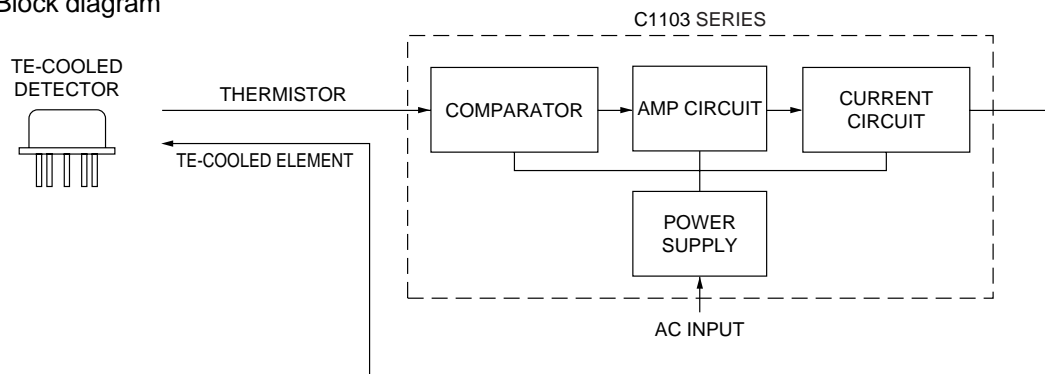

KIRDC0008EB

**CE**  
C1103-04 conforms to European EMC directives (89/336/EEC) and LVD (73/23/EEC).

KOTH0005EA

**SOLID STATE DIVISION**

**Valve operator for metal dewar A3515**

With this valve operator, metal dewars can be re-evacuated to maintain the desired vacuum level. Refer to the instruction manual for details.

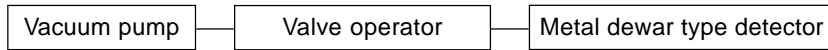
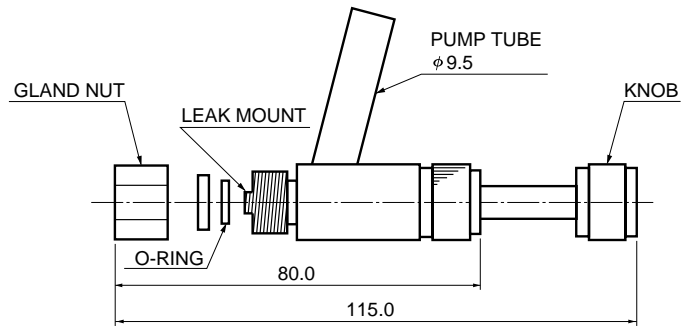
**Dimensional outline (unit: mm)**

KIRDA0021EB

## Heatsink for TE-cooled detector (TO-8, TO-3 package) **A3179 series**

These heatsinks are designed for use with thermoelectrically cooled detector sealed in a 6-pin TO-8, TO-3 package. The cooling (heat dissipation) capacity of A3179 and A3179-03 is about 35 °C relative to the ambient temperature 25 °C, A3179-01 is about 40 °C, and that of A3179-04 is about 85 °C. A3179-03 is designed only for two-color detector K3413 series, A3179, A3179-01 for TO-8, A3179-04 for TO-3.

■ Dimensional outlines (unit: mm, tolerance unless otherwise noted: ±1)

### A3179

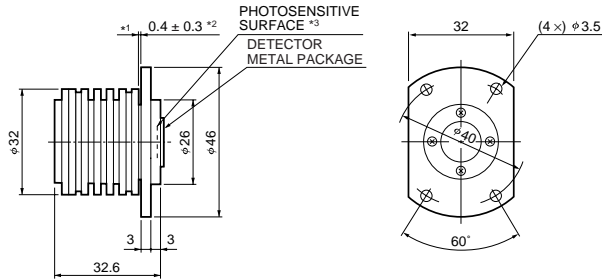

Weight: 50 g approx.

- \*1: Bottom surface (reference surface) of detector metal package
- \*2: When detector element is installed.
- \*3: The position of the photosensitive surface differs according to the detector element used.  
Refer to the dimensional outline for the detector.

KIRDA0018EC

### A3179-01, A3179-03

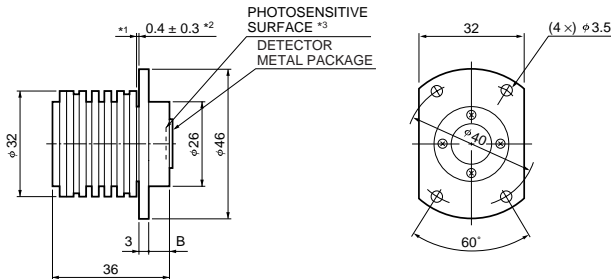

A3179-01: B=6  
A3179-03: B=6.4  
Weight: 53 g approx.

- \*1: Bottom surface (reference surface) of detector metal package
- \*2: When detector element is installed.
- \*3: The position of the photosensitive surface differs according to the detector element used.  
Refer to the dimensional outline for the detector.

KIRDA0019EC

### A3179-04

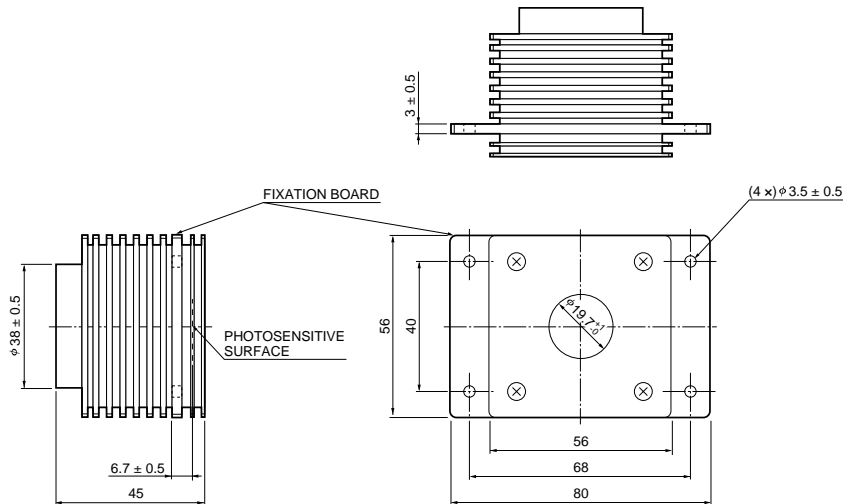

Weight: 320 g approx.

KIRDA0149EB

## Chopper C4696

### ■ Specifications

Parameter		Specification
Chopping frequency *1		115 to 380 Hz, 345 Hz Typ. *2
Power supply (V <sub>D</sub> )		DC 5 to 13 V, 12 V Typ.
Duty ratio		1: 1
Rotational stability		0.06 %/°C
Sync signal (high level)	Min.	V <sub>D</sub> - 0.5 V
	Max.	V <sub>D</sub> - 0.2 V
Operating temperature		0 to 50 °C
Maximum current consumption *2		90 mA
Accessory		Magnet stand A1447

\*1: Chopping frequency will be 230 to 760 Hz when an optional disc is used.

\*2: V<sub>D</sub>=12 V

### ■ Dimensional outline (unit: mm)

<CHOPPER>

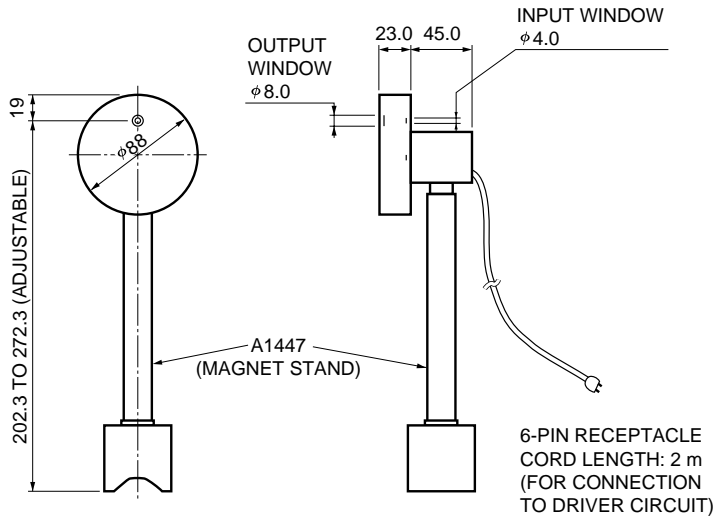

<DRIVER CIRCUIT>

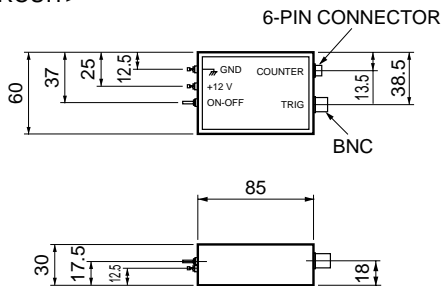

KIRDA0022EA

**Magnet stand A1447**

## ■ Dimensional outline (unit: mm)

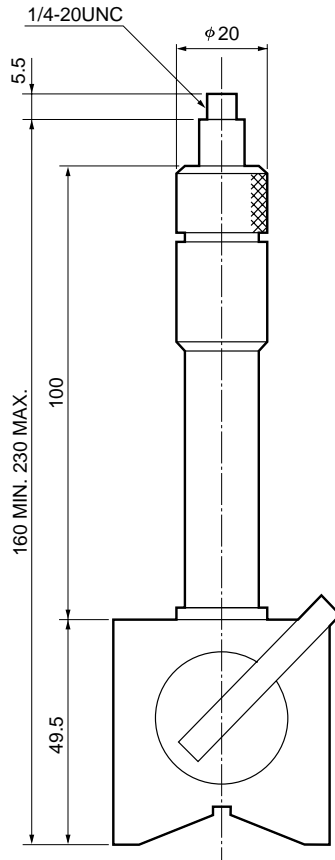

KIRDA0017EA

**HAMAMATSU**

Information furnished by HAMAMATSU is believed to be reliable. However, no responsibility is assumed for possible inaccuracies or omissions. Specifications are subject to change without notice. No patent rights are granted to any of the circuits described herein. ©2008 Hamamatsu Photonics K.K.

HAMAMATSU PHOTONICS K.K., Solid State Division

1126-1 Ichino-cho, Higashi-ku, Hamamatsu City, 435-8558 Japan, Telephone: (81) 53-434-3311, Fax: (81) 53-434-5184, www.hamamatsu.com

U.S.A.: Hamamatsu Corporation: 360 Foothill Road, P.O.Box 6910, Bridgewater, N.J. 08807-0910, U.S.A., Telephone: (1) 908-231-0960, Fax: (1) 908-231-1218

Germany: Hamamatsu Photonics Deutschland GmbH: Arzbergerstr. 10, D-82211 Herrsching am Ammersee, Germany, Telephone: (49) 08152-3750, Fax: (49) 08152-2658

France: Hamamatsu Photonics France S.A.R.L.: 19, Rue du Saule Trapu, Parc du Moulin de Massy, 91882 Massy Cedex, France, Telephone: 33-(1) 69 53 71 00, Fax: 33-(1) 69 53 71 10

United Kingdom: Hamamatsu Photonics UK Limited: 2 Howard Court, 10 Tewin Road, Welwyn Garden City, Hertfordshire AL7 1BW, United Kingdom, Telephone: (44) 1707-294888, Fax: (44) 1707-325777

North Europe: Hamamatsu Photonics Norden AB: Smidesvägen 12, SE-171 41 Solna, Sweden, Telephone: (46) 8-509-031-00, Fax: (46) 8-509-031-01

Italy: Hamamatsu Photonics Italia S.R.L.: Strada della Moia, 1/E, 20020 Arese, (Milano), Italy, Telephone: (39) 02-935-81-733, Fax: (39) 02-935-81-741