

Metal Package PMT

Photosensor Modules H9858 Series

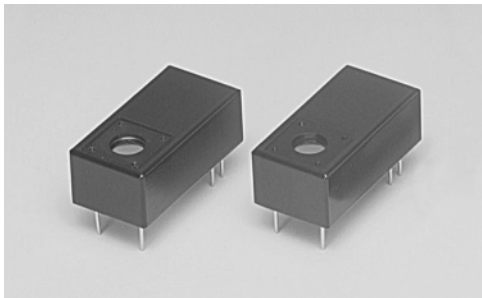

The H9858 series are photosensor modules housing a metal package PMT and high-voltage power supply circuit. The metal package PMTs have a metallic package with the same diameter as a TO-8 package used for semiconductor photodiodes, and deliver high gain, wide dynamic range and high-speed response while maintaining small dimensions identical to those of photodiodes. The internal high-voltage power supply circuit is also compact, making the module easy to use. A P-type is also available with selected gain and dark count ideal for photon counting under extremely low light conditions.

Compared to the previous types, the power consumption is reduced to 1/15* and the weight to 2/3, making the H9858 series ideal for portable measurement devices.

* Input Voltage=+3.0 V, Control Voltage=+0.8V

Product Variations

| Suffix | Spectral Response |
|--------|-------------------|
| None | 300 nm to 650 nm |
| -01 | 300 nm to 850 nm |
| -02 | 300 nm to 880 nm |
| -03 | 185 nm to 650 nm |
| -04 | 185 nm to 850 nm |
| -06 | 185 nm to 650 nm |
| -20 | 300 nm to 920 nm |

The suffix -06 type (synthetic silica window) has higher sensitivity than the -03 type below 300 nm in wavelength range.

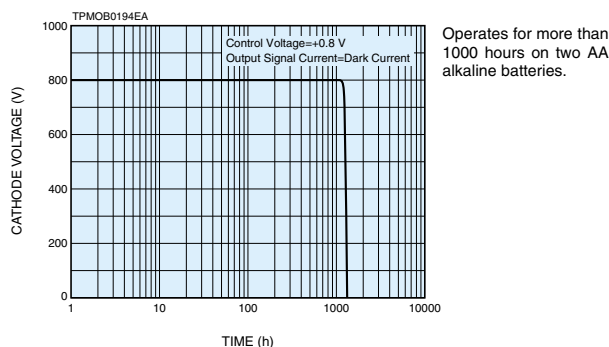

Specifications

| Parameter | | H9858 Series | | | | | Unit | |
|--|----------------------------------|-------------------------------|--|-----------------------|-----------------------|-----------------------|-----------------------|-----------------|
| Suffix | | None | -03, -06 | -01, -04 | -02 | -20 | — | |
| Input Voltage *1 | | +2.0 to +5.0 | | | | | V | |
| Max. Input Voltage | | +5.5 | | | | | V | |
| Max. Input Current *2 | | 2.7 | | | | | mA | |
| Max. Output Signal Current *3 *4 | | 100 | | | | | μA | |
| Max. Control Voltage | | +1.0 (Input impedance 100 kΩ) | | | | | V | |
| Recommended Control Voltage Adjustment Range | | +0.25 to +0.9 | | | | | V | |
| Effective Area | | φ8 | | | | | mm | |
| Sensitivity Adjustment Range | | 1: 10 ⁴ | | | | | — | |
| Peak Sensitivity Wavelength | | 420 | 420 | 400 | 500 | 630 | nm | |
| Cathode | Luminous Sensitivity | Min. 40 Typ. 70 | 40 70 | 80 150 | 200 250 | 350 500 | μA/lm | |
| | Blue Sensitivity Index (CS 5-58) | Typ. 8 | 8 | — | — | — | | |
| | Red/White Ratio | Typ. — | — | 0.2 | 0.25 | 0.45 | — | |
| | Radiant Sensitivity *5 | Typ. 62 | 62 | 60 | 58 | 78 | mA/W | |
| Anode | Standard Type | Luminous *3 Sensitivity | Min. 10 Typ. 50 | 10 50 | 15 75 | 25 125 | 35 250 | A/lm |
| | | Radiant Sensitivity *3 *5 | Typ. 4.3 × 10 ⁴ | 4.3 × 10 ⁴ | 3.0 × 10 ⁴ | 2.9 × 10 ⁴ | 3.9 × 10 ⁴ | |
| | P Type | Dark Current *3 *6 | Typ. 0.2 Max. 2 | 0.2 2 | 0.4 4 | 2 20 | 2 20 | nA |
| | | Gain *3 | Min. 7.5 × 10 ⁵ Typ. 1 × 10 ⁶ | — | — | — | — | |
| | P Type | Radiant Sensitivity *3 *5 | Typ. 6.2 × 10 ⁴ | — | — | — | — | A/W |
| | | Dark Count *3 *6 | Typ. 50 Max. 100 | — | — | — | — | s ⁻¹ |
| Rise Time *3 | Typ. | 0.78 | | | | | ns | |
| Ripple Noise *3 *7 (peak to peak) | Max. | 0.6 | | | | | mV | |
| Settling Time *8 | Max. | 10 | | | | | s | |
| Operating Ambient Temperature *9 | | +5 to +50 | | | | | °C | |
| Storage Temperature *9 | | -20 to +50 | | | | | °C | |
| Weight | | 45 | | | | | g | |

*1: At output current = 1 μA. We recommend setting the input voltage to 2.5 V or more when output current is 10 μA or more.

*2: Input voltage = +3.0 V, Control voltage = +0.8 V, Output signal current = Dark current *3: Control voltage = +0.8 V

*4: Input voltage > +2.1 V *5: Measured at the peak sensitivity wavelength *6: After 30 minutes storage in darkness

*7: Cable RG-174/U, Cable length 450 mm, Load resistance = 1 MΩ, Load capacitance = 22 pF

*8: The time required for the output to reach a stable level following a change in the control voltage from +1.0 V to +0.5 V.

*9: No condensation

Current Output Type Photosensor Modules

Characteristics (Cathode radiant sensitivity, Gain, Battery operation, Operation at 10 μA output)

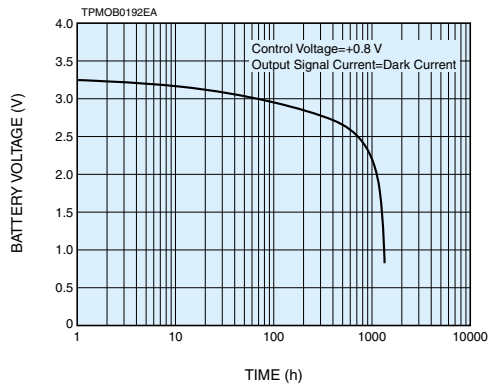
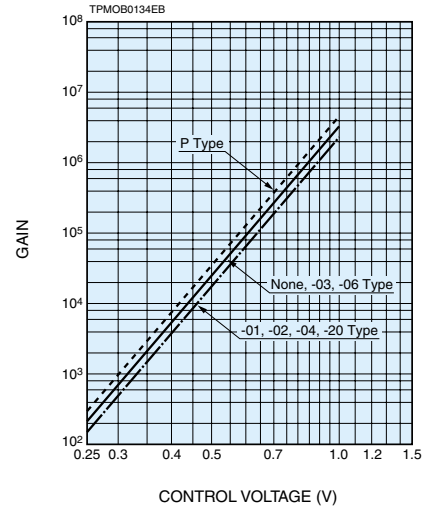
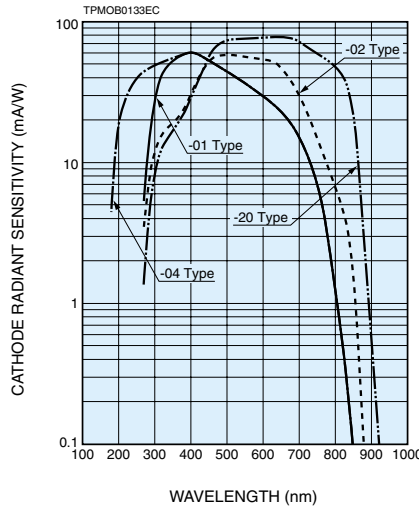
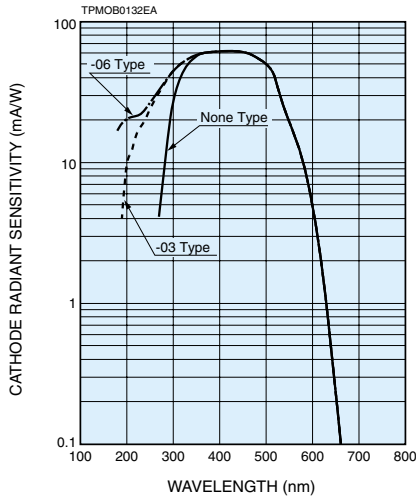

Battery voltage characteristics when two AA alkaline batteries are used.

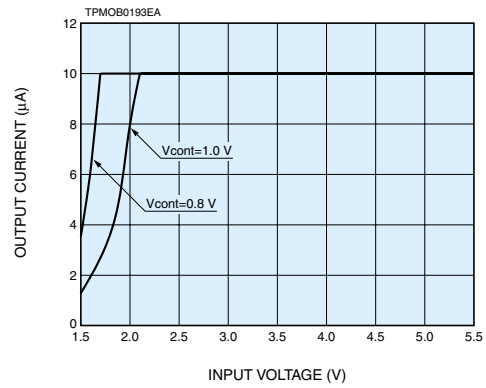

Sensitivity Adjustment Method

VOLTAGE PROGRAMMING

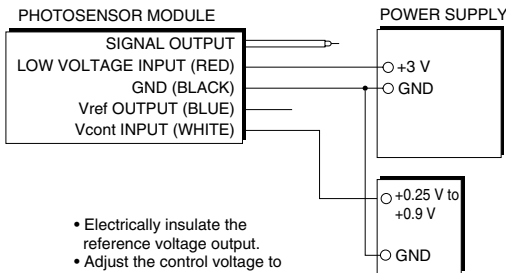

- Electrically insulate the reference voltage output.
- Adjust the control voltage to adjust the sensitivity.

RESISTANCE PROGRAMMING

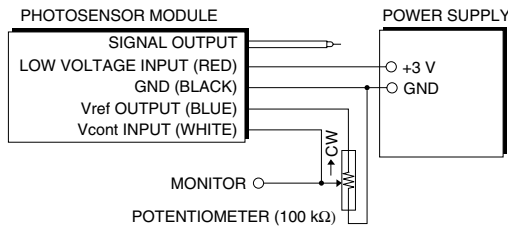

When using a potentiometer to adjust sensitivity, monitor the control voltage so it does not exceed +1.0 V.

TPMOC0196EA

Dimensional Outlines (Unit: mm)

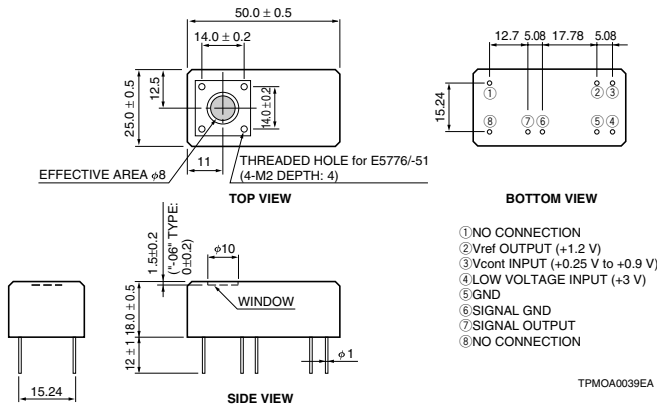

TPMOA0039EA

Options (Optical Fiber Adapter) (Unit: mm)

E5776 (FC Type)

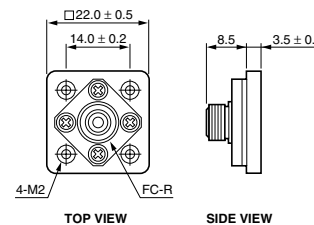

TACCA0055EA

E5776-51 (SMA Type)

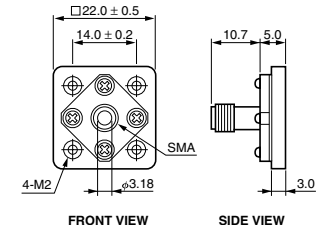

TACCA0239EA

* Evaluation board C10065 is available.