

Si photodiode S9682, S9683

Highly reliable photodiode for VUV detection

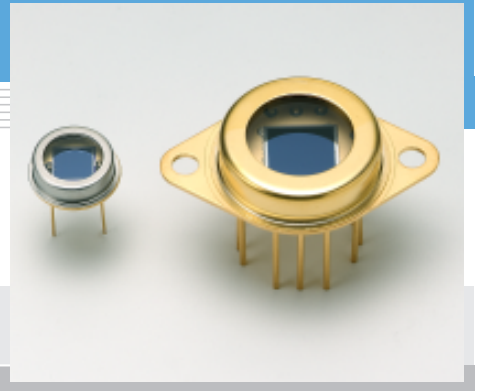

S9682 and S9683 are Si photodiodes specifically designed to detect VUV (vacuum ultraviolet) radiation with high reliability. These photodiodes are hermetically sealed in a metal package with a quartz window. There is no outgassing from the inside of the package, eliminating the cause of decrease in VUV sensitivity.

Features

- Highly stable sensitivity and dark current against ArF excimer laser radiation ($\lambda=193$ nm)
- Hermetically sealed metal package with quartz window
- Large active area:
S9682: 5.8 × 5.8 mm (TO-8 metal package)
S9683: 10 × 10 mm (1 inch metal package)

Applications

- ArF excimer laser detection
- UV detection

■ Absolute maximum ratings (Ta=25 °C)

Parameter	Symbol	Value	Unit
Reverse voltage	VR Max.	5	V
Operating temperature	Topr	-40 to +100	°C
Storage temperature	Tstg	-55 to +125	°C

■ Electrical and optical characteristics (Ta=25 °C)

Parameter	Symbol	Condition	S9682			S9683			Unit
			Min.	Typ.	Max.	Min.	Typ.	Max.	
Spectral response range	λ		-	193 to 1000	-	-	193 to 1000	-	nm
Peak sensitivity wavelength	λ_p		-	760	-	-	760	-	nm
Photo sensitivity	S	$\lambda=193$ nm	45	60	-	45	60	-	mA/W
Dark current	ID	VR=10 mV	-	0.02	0.5	-	0.05	1.0	nA
Terminal capacitance	Ct	VR=0 V, f=10 kHz	-	1.0	-	-	4.0	-	nF
Rise time	tr	VR=0 V, RL=1 k Ω 10 to 90 %	-	2	-	-	9	-	μ s

■ Variation in sensitivity due to VUV exposure

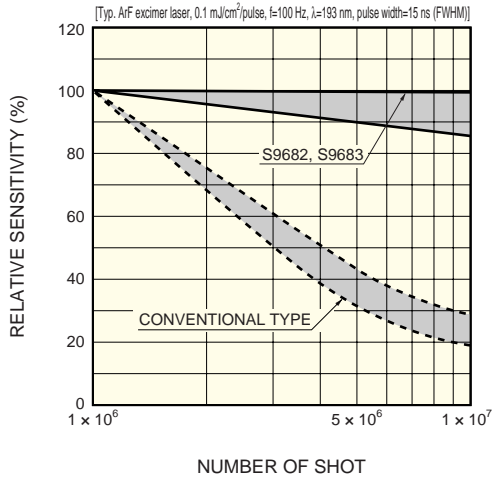

KSPDB0254EA

■ Dimensional outlines (unit: mm)

S9682

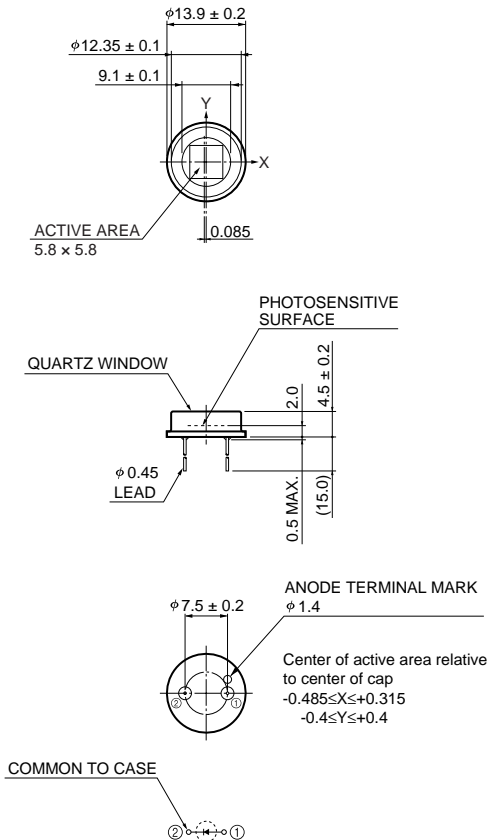

KSPDA0165EB

S9683

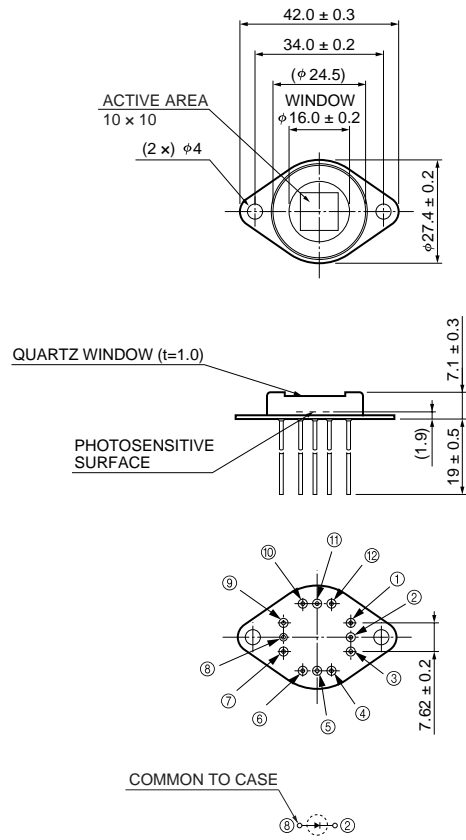

KSPDA0166EA

HAMAMATSU

Information furnished by HAMAMATSU is believed to be reliable. However, no responsibility is assumed for possible inaccuracies or omissions. Specifications are subject to change without notice. No patent rights are granted to any of the circuits described herein. ©2006 Hamamatsu Photonics K.K.

HAMAMATSU PHOTONICS K.K., Solid State Division

1126-1 Ichino-cho, Hamamatsu City, 435-8558 Japan, Telephone: (81) 053-434-3311, Fax: (81) 053-434-5184, www.hamamatsu.com

U.S.A.: Hamamatsu Corporation, 360 Foothill Road, P.O.Box 6910, Bridgewater, N.J. 08807-0910, U.S.A., Telephone: (1) 908-231-0960, Fax: (1) 908-231-1218

Germany: Hamamatsu Photonics Deutschland GmbH, Arzbergerstr. 10, D-82211 Herrsching am Ammersee, Germany, Telephone: (49) 08152-3750, Fax: (49) 08152-2658

France: Hamamatsu Photonics France S.A.R.L.: 8, Rue du Saule Trapu, Parc du Moulin de Massy, 91882 Massy Cedex, France, Telephone: 33-(1) 69 53 71 00, Fax: 33-(1) 69 53 71 10

United Kingdom: Hamamatsu Photonics UK Limited, 2 Howard Court, 10 Tewin Road, Welwyn Garden City, Hertfordshire AL7 1BW, United Kingdom, Telephone: (44) 1707-294888, Fax: (44) 1707-325777

North Europe: Hamamatsu Photonics Norden AB, Smidsvågen 12, SE-171 41 Solna, Sweden, Telephone: (46) 8-509-031-00, Fax: (46) 8-509-031-01

Italy: Hamamatsu Photonics Italia S.R.L.: Strada della Moia, 1/E, 20020 Arese, (Milano), Italy, Telephone: (39) 02-935-81-733, Fax: (39) 02-935-81-741