

# CMOS linear image sensor S8377/S8378 series

Built-in timing generator and signal processing circuit; single 5 V supply operation



S8377/S8378 series is a family of CMOS linear image sensors designed for image input applications. These linear image sensors operate from single 5 V supply with only start and clock pulse inputs, making them easy to use. The signal processing circuit has a charge amplifier with excellent input/output characteristics and allows signal readout at 500 kHz.

The photodiodes of S8377 series have a height of 0.5 mm and are arrayed in a row at a spacing of 50  $\mu\text{m}$ . The photodiodes of S8378 series also have a height of 0.5 mm but are arrayed at a spacing of 25  $\mu\text{m}$ . The photodiodes are available in 3 different pixel quantities for each series: 128 (S8377-128Q), 256 (S8377-256Q, S8378-256Q), 512 (S8377-512Q, S8378-512Q) and 1024 (S8378-1024Q). Quartz glass is the standard window material.

## Features

- Wide active area  
Pixel pitch: 50  $\mu\text{m}$  (S8377 series)  
25  $\mu\text{m}$  (S8378 series)  
Pixel height: 0.5 mm
- On-chip charge amplifier with excellent input/output characteristics
- Built-in timing generator allows operation with only start and clock pulse inputs
- Maximum operating clock frequency: 500 kHz
- Spectral response range: 200 to 1000 nm
- Single 5 V power supply operation
- 8-pin small package, S8377 and S8378 series are pin compatible.

## Applications

- Image input devices
- Optical sensing devices

### Absolute maximum ratings

Parameter	Symbol	Value	Unit
Supply voltage	V <sub>dd</sub>	-0.3 to +10	V
Gain selection terminal voltage	V <sub>g</sub>	-0.3 to +10	V
Clock pulse voltage	V (CLK)	-0.3 to +10	V
Start pulse voltage	V (ST)	-0.3 to +10	V
Operating temperature *1	T <sub>opr</sub>	-20 to +60	°C
Storage temperature	T <sub>stg</sub>	-20 to +80	°C

\*1: No condensation

### Shape specifications

Parameter	S8377-128Q	S8377-256Q	S8377-512Q	S8378-256Q	S8378-512Q	S8378-1024Q	Unit
Number of pixels	128	256	512	256	512	1024	-
Pixel pitch	50			25			$\mu\text{m}$
Pixel height	0.5						mm
Package length	15.8	22.2	35.0	15.8	22.2	35.0	mm
Number of pins	8			8			-
Window material	Quartz			Quartz			-

■ Recommended terminal voltage

Parameter	Symbol	Min.	Typ.	Max.	Unit
Supply voltage	Vdd	4.75	5	5.25	V
Gain selection terminal voltage	High gain	0	-	0.4	V
	Low gain	Vdd-0.25	Vdd	Vdd+0.25	V
Clock pulse voltage	High	Vdd-0.25	Vdd	Vdd+0.25	V
	Low	0	-	0.4	V
Start pulse voltage	High	Vdd-0.25	Vdd	Vdd+0.25	V
	Low	0	-	0.4	V

■ Electrical characteristics

Parameter	Symbol	Min.	Typ.	Max.	Unit
Clock pulse frequency *2	f (CLK)	0.1	-	500	kHz
Output impedance *3	Zo	-	1	-	kΩ
Power consumption	P	-	25	-	mW

\*2: Ta=25 °C, Vdd=5 V, V (CLK)=V (ST)=5 V, Vg=5 V (Low gain)

\*3: An increased current consumption at the video terminal rises the sensor chip temperature causing an increased dark current. Connect a buffer amplifier for impedance conversion to the video terminal so that the current flowing to the video terminal is minimized.

Use a JFET or CMOS input, high-impedance input op amp as the buffer amplifier.

■ Electrical and optical characteristics [Ta=25 °C, Vdd=5 V, V (CLK)=V (ST)=5 V]

Parameter	Symbol	S8377 series			S8378 series			Unit	
		Min.	Typ.	Max.	Min.	Typ.	Max.		
Spectral response range	λ	200 to 1000			200 to 1000			nm	
Peak sensitivity wavelength	λp	-	500	-	-	500	-	nm	
Photo sensitivity	High gain	-	22	-	-	22	-	V/lx·s	
	Low gain	-	4.4	-	-	4.4	-		
Dark current	Id	-	0.08	0.24	-	0.04	0.12	pA	
Saturation charge	Qsat	-	12.5	-	-	6.3	-	pC	
Feedback capacitance *4 of charge amplifier	High gain	-	1	-	-	0.5	-	PF	
	Low gain	-	5	-	-	2.5	-		
Dark output voltage *5	High gain	-	8.0	24	-	8.0	24	mV	
	Low gain	-	1.6	4.8	-	1.6	4.8		
Saturation output voltage	High gain	2.8	3.2	-	2.8	3.2	-	V	
	Low gain	2.1	2.5	-	2.1	2.5	-		
Saturation exposure *6	High gain	-	145	-	-	145	-	mlx·s	
	Low gain	-	570	-	-	570	-		
Readout noise	Low gain	Nr	-	0.1 (-128Q)	-	-	0.2 (-256Q)	-	mV rms
			-	0.15 (-256Q)	-	-	0.3 (-512Q)	-	
			-	0.2 (-512Q)	-	-	0.4 (-1024Q)	-	
			-	0.4 (-128Q)	-	-	0.9 (-256Q)	-	
			-	0.5 (-256Q)	-	-	1.3 (-512Q)	-	
Photo response non-uniformity *7	PRNU	-3	-	+3	-3	-	+3	%	

\*4: Vg=5 V (Low gain), Vg=0 V (High gain)

\*5: Storage time Ts=100 ms

\*6: Measured with a tungsten lamp of 2856 K.

\*7: Photo response non-uniformity is defined under the condition that the device is uniformly illuminated by light which is 50 % of the saturation exposure level as follows:

$$PRNU = \frac{\Delta X}{X} \times 100 (\%)$$

X: the average output of all pixels, ΔX: difference between X and maximum or minimum output and X

■ Spectral response (typical example)

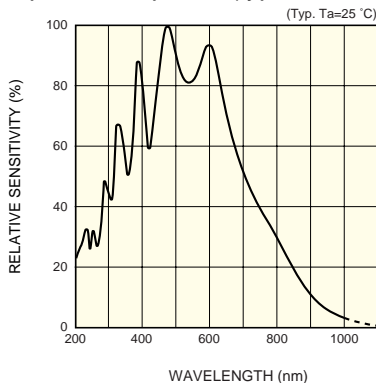

KMPDB0213EB

■ Timing chart

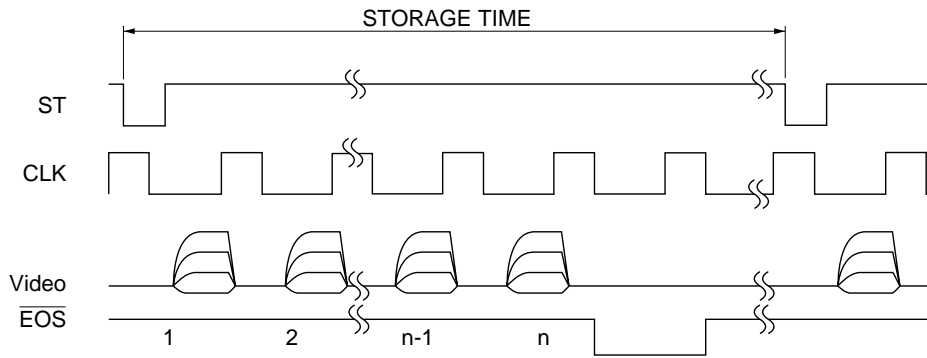

The storage time is determined by the start pulse intervals. However, since the charge storage of each pixel is carried out between the signal readout of that pixel and the next signal readout of the same pixel, the start time of charge storage differs depending on each pixel. In addition, the next start pulse cannot be input until signal readout from all pixels is completed.

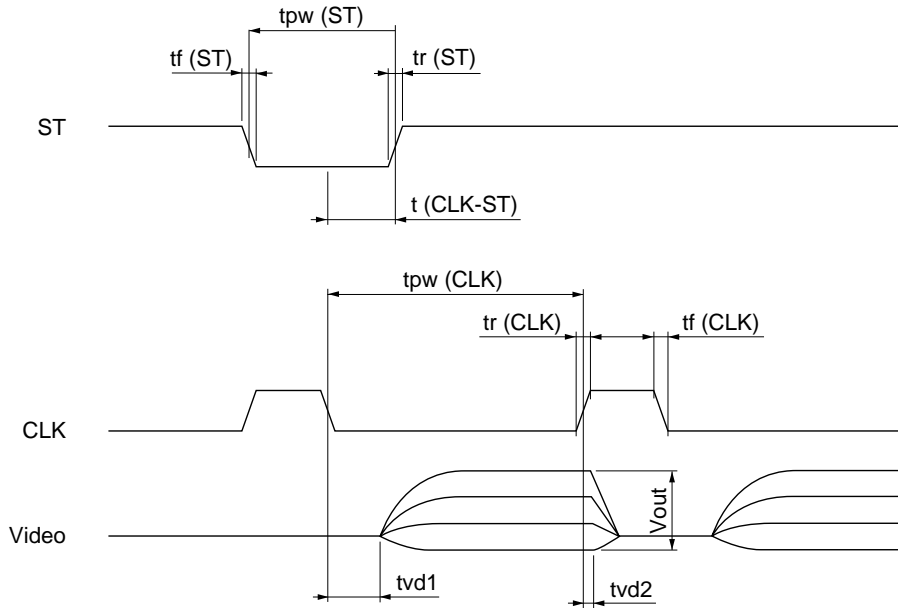

KMPDC0149EA

Parameter	Symbol	Min.	Typ.	Max.	Unit
Start pulse width	$t_{pw}$ (ST)	600 ns	-	10 ms	-
Start pulse rise and fall time	$t_r$ (ST), $t_f$ (ST)	0	20	30	ns
Clock pulse width	$t_{pw}$ (CLK)	1000 ns	-	5 ms	-
Clock pulse rise and fall time	$t_r$ (CLK), $t_f$ (CLK)	0	20	30	ns
Clock pulse-start pulse timing	$t$ (CLK-ST)	400 ns	-	5 ms	-
Video delay time 1	$t_{vd1}$	200	300	400	ns
Video delay time 2	$t_{vd2}$	50	150	250	ns

■ Block diagram

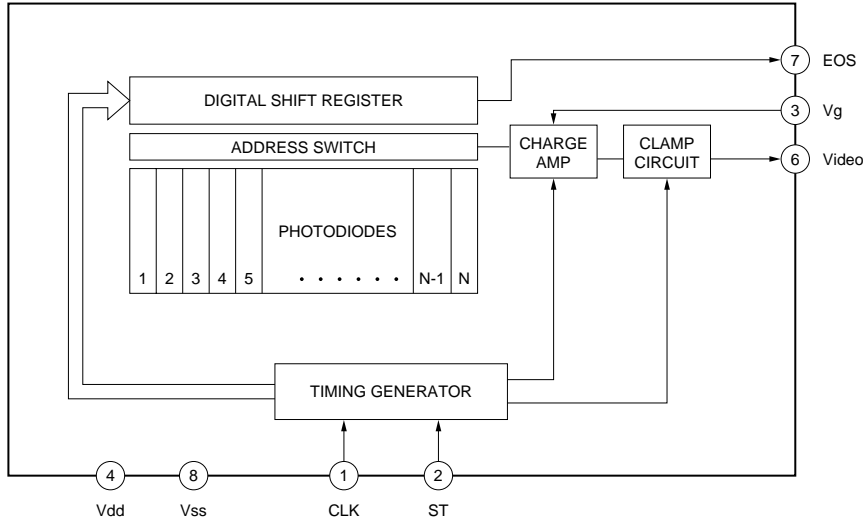

KMPDC0150EA

■ Pin connections

Pin No.	Symbol	Name of pin	Function
1	CLK	Clock pulse	Pulse input to operate the shift register. The readout time (data rate) equals the clock pulse frequency.
2	ST	Start pulse	Starts the shift register operation. The start pulse intervals determine the signal storage time.
3	Vg	Gain selection voltage	Input of 5 V selects "Low gain" and 0 V selects "High gain"
4	Vdd	Supply voltage	5 V Typ.
5	NC		Open
6	Video	Video	Signal output. Positive-going output from 1 V
7	$\overline{\text{EOS}}$	End of scan	Negative-going signal output obtained at a timing following the last pixel scan.
8	Vss	Ground	

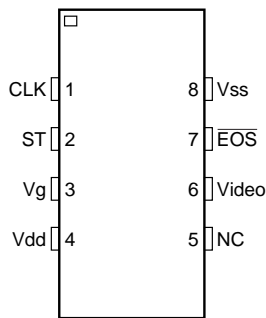

KMPDC0151EA

■ Dimensional outlines (unit: mm)

S8377-128Q, S8378-256Q

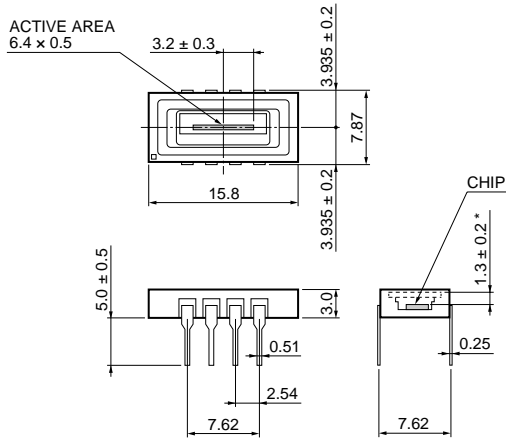

\* Optical distance from the outer surface of the quartz window to the chip surface

KMPDA0150EC

S8377-256Q, S8378-512Q

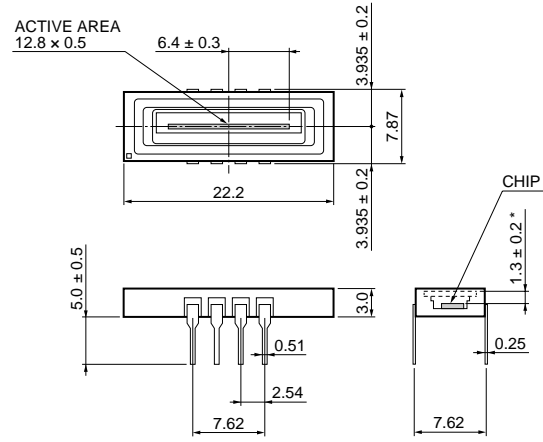

\* Optical distance from the outer surface of the quartz window to the chip surface

KMPDA0151EC

S8377-512Q, S8378-1024Q

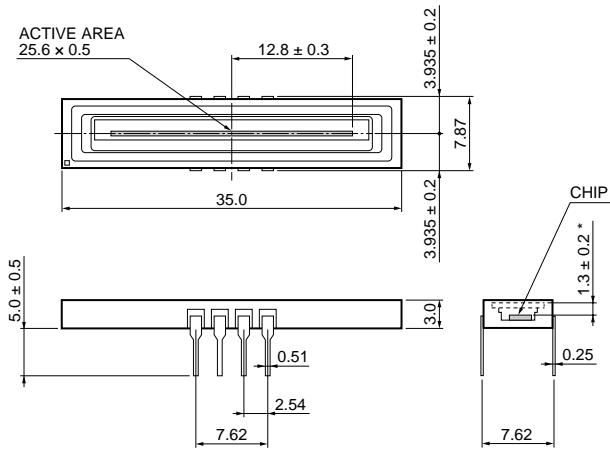

\* Optical distance from the outer surface of the quartz window to the chip surface

KMPDA0152EC

■ Handling precautions

(1) Electrostatic countermeasures

Although the CMOS linear image sensor is protected against static electricity, proper electrostatic countermeasures must be provided to prevent device destruction by static electricity. For example, such measures include wearing non-static gloves and clothes, and grounding the work area and tools.

(2) Incident window

If the incident window is contaminated or scratched, the output uniformity will deteriorate considerably, so care should be taken in handling the window. Avoid touching it with bare hands.

The window surface should be cleaned before using the device. If dry cloth or dry cotton swab is used to rub the window surface, static electricity may be generated, and therefore this practice should be avoided. Use soft cloth, cotton swab or soft paper moistened with ethyl alcohol to wipe off dirt and foreign matter on the window surface.

(3) UV exposure

The CMOS linear image sensor is designed to suppress performance deterioration due to UV exposure. Even so, avoid unnecessary UV exposure to the device.

Also, be careful not to allow UV light to strike the cemented portion between the ceramic base and the glass.

(4) Operating and storage environments

Always observe the rated temperature range when handling the device. Operating or storing the device at an excessively high temperature and humidity may cause variations in performance characteristics and must be avoided.